

REPIPE

Pipe, Connections & Valves

"Connecting Australia"

LIFT CHECK VALVE

ISO 9001 CERTIFIED COMPANY

LIFT CHECK VALVE

FEATURES

- Suitable For Industrial, Pneumatic and Hydraulic Installations
- Ideal For Hot/ Cold Water, Different Oils and Compressed Air
- Can Be Fitted in Horizontal, Vertical or Oblique Position



TECHNICAL DATA

- Code: VCLR-(size DN)
- Size Range: DN10 – DN100
- Working Temp Range: -20°C to 110°C (Air)
0°C to 90°C (Water)
-20°C to 60°C (Gas)
- Thread: ISO228 – DIN259 – BS2779

MATERIALS

- Body: Brass CW 617N
- Internal Seat: Stainless Steel Plate AISI 304 Fitted With NBR 60 SH/A, Cover Plate and Rod in Brass CW 614N
- Spring: Stainless Steel AISI 302

DIMENSIONS

SIZE (DN)	H	L	Approx. Wt (kg)	kPa
10	55.0	34.5	0.17	2482
15	58.5	34.5	0.19	2482
20	65.0	41.5	0.27	2482
25	74.5	48.0	0.43	2482
32	83.0	60.5	0.54	1793
40	93.0	71.0	0.87	1793
50	101.0	87.0	1.32	1793
65	122.0	120.0	2.62	1172
80	141.5	140.5	4.21	1172
100	158.5	172.5	6.13	1172

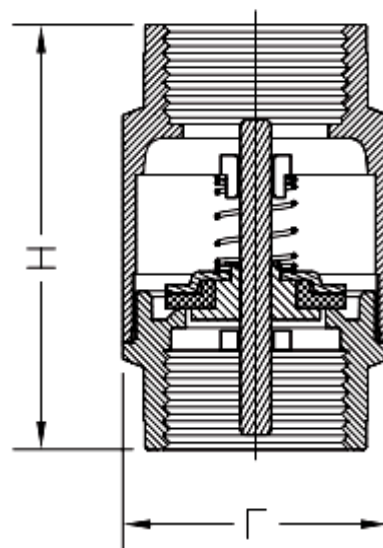

SYDNEY- NEWCASTLE – PERTH – 1300 362 954 – sales@repipe.com.au

Distributors of Quality Products Australia Wide

The data provided here is for information purposes only. Repipe reserves the right to change or modify this data without prior notice.

Y:\CATALOGUE & DATA SHEETS - MASTER\Datasheet Masters\FIRE\Lift Check Valve.docx