

REPIPE

Pipe, Connections & Valves

Connecting Australia

SWING ARM FIRE HOSE REEL

ISO 9001 CERTIFIED COMPANY

SWING ARM FIRE HOSE REEL

FEATURES

- Fixed Waterway
- Full Centre Drum Spindle
- Heavy Duty Connection Block
- Quick Wall Bracket Installation
- 36m x 19mm Tested Black Hose
- Brass Ball Valve Included
- Hose Reel Guide Included
- Hose Reels Have Been Performance Tested and Approved to AS/NZ 1221:1997

ACCESSORIES AVAILABLE

- Hose Reel Stands
- Hose Reel Covers
- Replacement Parts
- Cabinets

TECHNICAL DATA

- Code: FFS-HRS-36B-SAF
- Test Pressure: 2.0 Mpa
- Min. Discharge Rate: 0.45 L/s

DIMENSIONS

Hose Length	Reel Height	Reel Depth	Weight
19mm x 36mm	460	190	20kg (Gross 22kg)



Model: CSJR-08-B

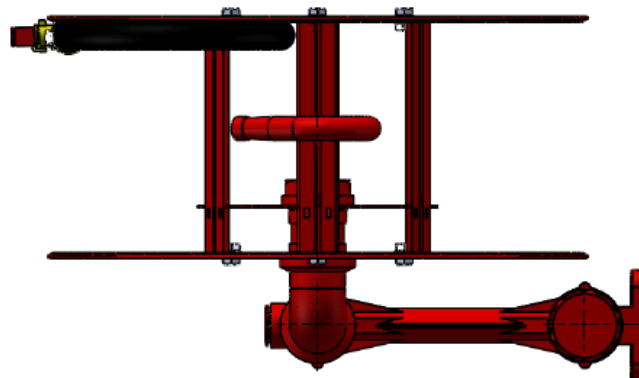
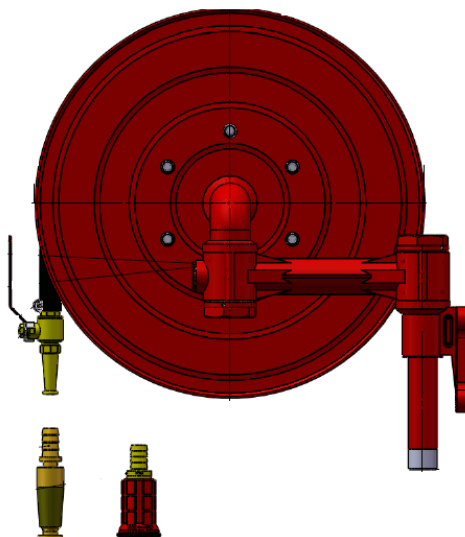

SYDNEY- NEWCASTLE – PERTH – 1300 362 954 – sales@repipe.com.au

Distributors of Quality Products Australia Wide

The data provided here is for information purposes only. Repipe reserves the right to change or modify this data without prior notice.

Y:\CATALOGUE & DATA SHEETS - MASTER\Datasheet Masters\FIRE\Swing Arm Fire Hose Reel.docx