

DN150 H-PATTERN STORZ SUCTION BOOSTER ASSEMBLY c/w DDCV Butterfly Valve – Tank Booster Design

FFS-150MMHSB-DDCV

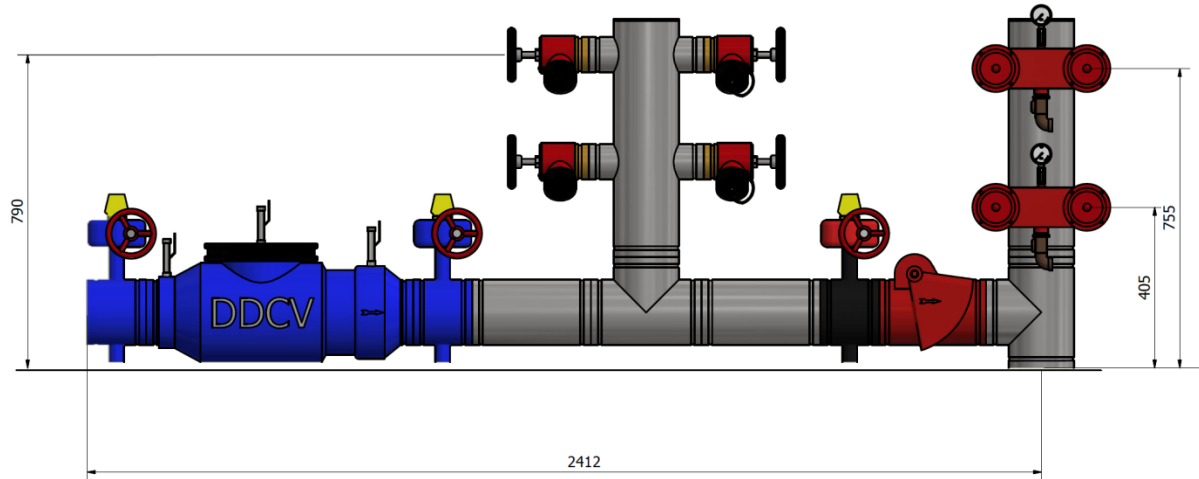

FEATURES

- Booster assemblies are manufactured to conform to the requirement of AS2419 & to relevant local authorities. All components comply to the requirements of AS2419.
- Any fabricated components are Hot Dipped Galvanised as required in AS2419.
- Backflow prevention devices can be supplied and designed into assemblies. Backflow devices comply to AS2845.1.
- All components will withstand pressure testing up to 2100kpa. (Note: Fire Brigade test pressure is 1700kpa.)
- All booster units can be supplied as individual components or fully/ part assembled.
- **Please nominate connections, LH or RH entry & either butterfly or gate valves required to suit relevant authority requirements.**

OPTIONS

- All assemblies can be custom built to comply with AS2419 where confined space is a problem.
- Copamate Flanges, Roll Grooved Flange Adaptors, Copper to RG Adaptors, Copper Long Leg Riser Elbows
- Hydrant booster cabinets are available for all booster configurations.
- Available in DN100, 150, 200 & 250.
- **Please note: Detailed PDF drawings available on request.**

SYDNEY- NEWCASTLE – PERTH – 1300 362 954 – sales@repipe.com.au

Distributors of Quality Products Australia Wide



The data provided here is for information purposes only. Repipe reserves the right to change or modify this data without prior notice.